

# TGS 203 - Carbon Monoxide Sensor Specifications

### 1. Structure and Dimensions

Please refer to the technical drawing shown in Figure 1. Specifications for component parts subject to Table I below.

### 2. Materials

Part numbers are as indicated in the technical drawing of Figure 1.

#	Part	Material
1	Stainless Steel Gauze	Stainless Steel SUS 304 (60 mesh)
2	Activated Charcoal Filter	20 ~ 40-mesh
3	Cover	Polyamide resin reinforced with glass fiber
4	Sensor Element	Metal oxide semiconductor
5	Flame-Proof Cover	Double layer of 100-mesh stainless steel gauze SUS 316
6	Coil	Paladium-Iridium alloy wire Diameter: 0.09mm
7	Base	Polyethylene terephthalate reinforced with glass fiber
8	Ring	Nickel plated brass ring
9	Pin	Nickel

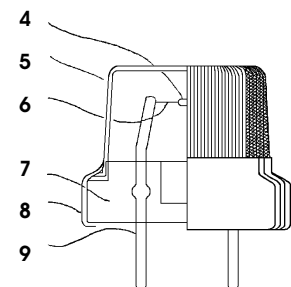
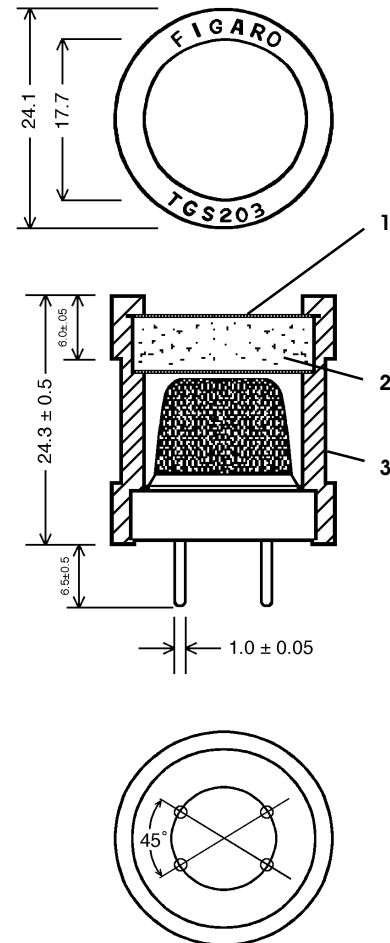

Cross section of internal sensing element

### 3. Explosion Proof

A spark inside the cover cannot ignite a gas leak outside of the cover.

### 4. Mechanical Strength

#### Connecting Strength

Using applied pressure, a ring is affixed to the base for the purpose of holding the flame proof cover in a fixed position.

#### Withdrawal Force

The pins can withstand a withdrawal force of more than 5 kgs applied in the direction of the pins.

Figure 1

## 5. Sensitivity Characteristics

Item	Symbol	Condition	Specification
Sensor Resistance	R <sub>s</sub>	CO at 100ppm	1kΩ ~ 15kΩ
Change Ratio of Sensor Resistance	R <sub>s</sub> /R <sub>o</sub>	$\frac{R_s \text{ (H}_2 \text{ at 1000ppm)}}{R_s \text{ (CO at 100ppm)}}$	> 1.0
Sensor Resistance Gradient	α	$\frac{\log (R_s \text{ in 100ppm CO}/R_s \text{ in 300ppm CO})}{\log (100\text{ppm CO}/300\text{ppm CO})}$	-1.50 ~ -0.73

## 6. Standard Test Conditions

The TGS-203 complies with the above listed electrical characteristics when the sensor is tested using the circuit illustrated at the right and under the standard conditions set forth in the table below. V<sub>RL</sub> shall be measured during the final 0.5 seconds of the low heater voltage period. The sensing unit shall be evaluated in the basic measuring circuit under the reference atmosphere immediately after a minimum of 96 hours of pre-heating.

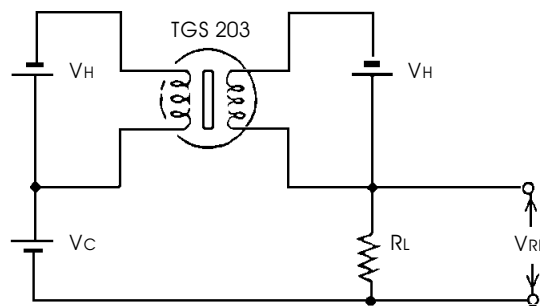

**Basic Measuring Circuit**

V<sub>c</sub> - Circuit voltage      R<sub>L</sub> - Load resistance  
V<sub>RL</sub> - Output voltage      V<sub>H</sub> - Heater voltage

**NOTE:** Test gas must have greater than 99.9% purity under ambient conditions of 20°C and 1 atm.

Item	Symbol	Rated Value	Remarks
Circuit Voltage	V <sub>c</sub>	5.0V ± 1%	DC
Heater	V <sub>H</sub>	V <sub>H</sub> H = 0.8V ± 3% for 60 ± 1 sec. V <sub>H</sub> L = 0.25V ± 3% for 90 ± 1 sec.	Must apply alternately for duration specified
	I <sub>H</sub>	I <sub>H</sub> H = 369mA ± 3% for 60 ± 1 sec. I <sub>H</sub> L = 133mA ± 3% for 90 ± 1 sec.	
Load Resistance	R <sub>L</sub>	4KΩ ± 1%	
Reference Atmosphere		20°C ± 2°C, 65% ± 5% RH	Test chamber must have > 1 liter capacity

Sensor Resistance (R<sub>s</sub>) is calculated by the following formula:

$$R_s = \frac{V_c - V_{RL}}{V_{RL}} \times R_L$$

Power dissipation across sensor electrodes (P<sub>s</sub>) is calculated by the following formula:

$$P_s = \frac{(V_c - V_{RL})^2}{R_s}$$

For information on warranty, please refer to Standard Terms and Conditions of Sale of Figaro USA Inc.

### FIGARO USA, INC.

3703 West Lake Ave. Suite 203  
Glenview, Illinois 60025  
Phone: (847)-832-1701  
Fax: (847)-832-1705  
email: figarousa@figarosensor.com